



Visit Us on the Web at [www.chatillon.com](http://www.chatillon.com)

# LTCM-500 Series High Capacity Motorized Tester (550 lbf, 2500N)

Specification Sheet  
SS-FM-3135-1006  
October 2006

The CHATILLON® LTCM-500 Series is an economical, motorized tester ideal for production environments, research & development laboratories and quality functions. The LTCM-500 may be used for tensile, compression, peel, and flexural testing when combined with a Chatillon DF Series force gauge. A large working area and 5-inch (130mm) throat is perfect for large sample testing. The platform features pre-drilled holes for custom fixturing or for use with Chatillon fixtures. The crosshead travel is selectable in either inches per minute or millimeters per minute. The speed range is 0.2 to 20 inches/min (5 to 500 mm/min). A dial is used to set the speed requirement and a digital display indicates the speed selected to 0.1 resolution. Crosshead travel is 29 inches (750mm). An Up and Down switch is used to control crosshead travel direction. A simple switch setting can be used to reverse crosshead speed direction at maximum speed at the completion of a test. An emergency stop is located on the console for easy access. Mechanical limits may be set to stop crosshead travel at a specified position. Rulers are provided on the front face and crosshead face of the column for accurate placement and for measuring extension. Positive braking ensures a precise stop.

## Features

- ❑ Tensile, Compressive, Peel & Flexural Testing
- ❑ Compact, Benchtop Design
- ❑ Simple Operation with Intuitive Controls
  - Crosshead Direction
  - Return Speed
  - Speed Selection
  - Emergency Stop
  - On/Off
- ❑ Load Limits (DF Force Gauge Driven)
- ❑ Large Working Area and Throat for Large Samples
- ❑ Selectable Display with Digital Speed Readout
  - Inches per Minute
  - Millimeters per Minute
- ❑ T-Slot Fixturing for Fast, Easy Testing
- ❑ Options include Splinter Shield & Footswitch Operation
- ❑ 2 Year Warranty

## Specifications

- Capacity:** 550 lbf (2500N)
- Crosshead Speed:** 0.2 to 20 in/min (5 to 500 mm/min)
- Speed Accuracy:** ±3% (No Load)
- Travel:** 29-inches (750mm)
- Load Measurement:** Chatillon Force Gauge
- Supply Voltage:** 110/230Vac
- Operating Temperature:** 40°F to 110°F (5°C to 45°C)
- Weight:** 100 lbs (45.5 kg) approx.



**You Get More with Your CHATILLON Gauge.**



A registered trademark of AMETEK Inc.

# LTCM-500 Features

## Easy Operation

### On/Off Switch

The LTCM-500 features a switchable power supply that can be adjusted for 115Vac or 230Vac source power. The tester's On/Off switch is located conveniently on the top of the console.

### Emergency Stop Switch

The Emergency Stop Switch is located on the top of the console, away from the crosshead or any moving parts. Depress the emergency switch to immediately stop the crosshead travel.

### LED Display

The high resolution, LCD segment display indicates travel speed, when a Load Limit has been achieved and diagnostic codes.

### Units of Measure Status Indicators

The LTCM-500 can indicate speed in inches per minute or mm per minute. A status indicator shows the speed unit associated with the displayed speed rate.

### Simple and Accurate Speed Control

The LTCM-500 console controls are intuitive and easy to use. Users can specify speed in either inches per minute or millimeters per minute. The speed control knob is used to adjust speed from 0.2 to 20.0 in/min or 0.5 to 500 mm/min. Speed accuracy is better than 3%. The Up and Down key is used to control crosshead direction.

### Independent Return Speed

A separate return speed switch can be positioned so that the crosshead returns to zero at maximum speed or at the speed indicated by the display.

### Adjustable Deflection Limits

Deflection limit switches are supplied on the front of the column. The column contains increments in inches and millimeters for positioning the limit switches and for measuring sample deflection. Position and "lock-in" a High and Low deflection limit to protect your gauge from overload conditions or for ending your test at a distance traveled. The crosshead travels up to 29-inches (750mm).

### Load Limits

When used with a Chatillon DF Series force gauge, the LTCM-500 can make use of the force gauge's limit outputs. When the force gauge measures a load limit (high or low), the gauge will send a command to the LTCM-500 that causes the tester's crosshead to stop traveling. This permits automated testing using load limits and helps prevent load sensor overload conditions. The display will indicate a Load Limit condition.





## Excellent Performance

### Production or Laboratory Environment

The LTCM-500's rugged construction and simple operation make it ideal for production environments, laboratory applications or for R&D applications. Combine with a Chatillon DFS Series force gauge and you have a force measurement system with a load accuracy of better than 0.1% full scale. The tester is ideal for tensile, compression, peel, shear, and flexural testing when used with the appropriate grips/fixtures.

### Long Crosshead Travel

The crosshead travel distance is 29 inches (750mm), ideal for testing large samples or samples with high elastic properties.

### Large Working Area

The LTCM-500 features a large working area capable of securing samples up to 10-inches in diameter. The crosshead throat is greater than 5-inches (127mm).

### Flexible Fixturing

The crosshead has been optimized for use with Chatillon DF Series digital forces gauges. The DFE and DFS Series mount directly to the crosshead without special adapters. The standard T-Slot base comes with a universal mounting block with #10-32, 1/4-28, 5/16-18 and M12 x 1.75 threads. The universal mounting block is indexed to ensure perfect center alignment.

### Mechanical Splinter Screen

The LTCM-500 may be equipped with an optional splinter screen. The splinter screen mounts easily to the LTCM-500 column and base assembly. A hinged door ensures quick and easy access to your sample. The splinter shield is made of clear Lexan.



*LTCM-500 shown with optional splinter screen.*

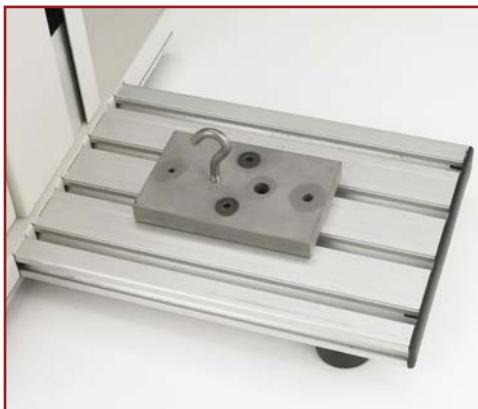

### Flexible Mounting Options

The LTCM-500 features a standard T-slot base that provides you with a variety of options for securing your sample during a test. A special mounting block contains different thread sizes to accommodate a wide assortment of fixtures, grips and accessories. The mounting block may be positioned within the T-Slot base to ensure proper sample alignment.



### Simple Mounting Block

Remote-type load sensors, such as the Chatillon SLC Load Sensor, are easily affixed to the LTCM-500 crosshead with an optional mounting block. The mounting block has multiple thread patterns that fit 10-32F, 1/4-28F, 1/2-20F sensors.



### Footswitch Controller

The LTCM-500 may be used with our optional footswitch controller. The controller plugs directly into the LTCM-500 and allows the user to control crosshead travel with a simple foot pedal. The footswitch is ideal for repetitive testing and provides added security for the operator. Cable is 8.33 ft. (100 inches).

# Dimensions - LTCM-500 Series

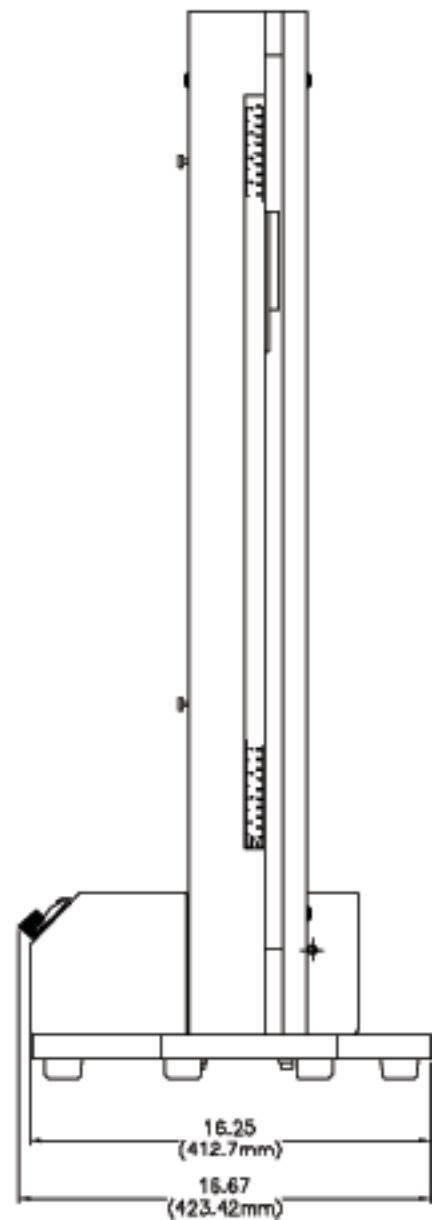
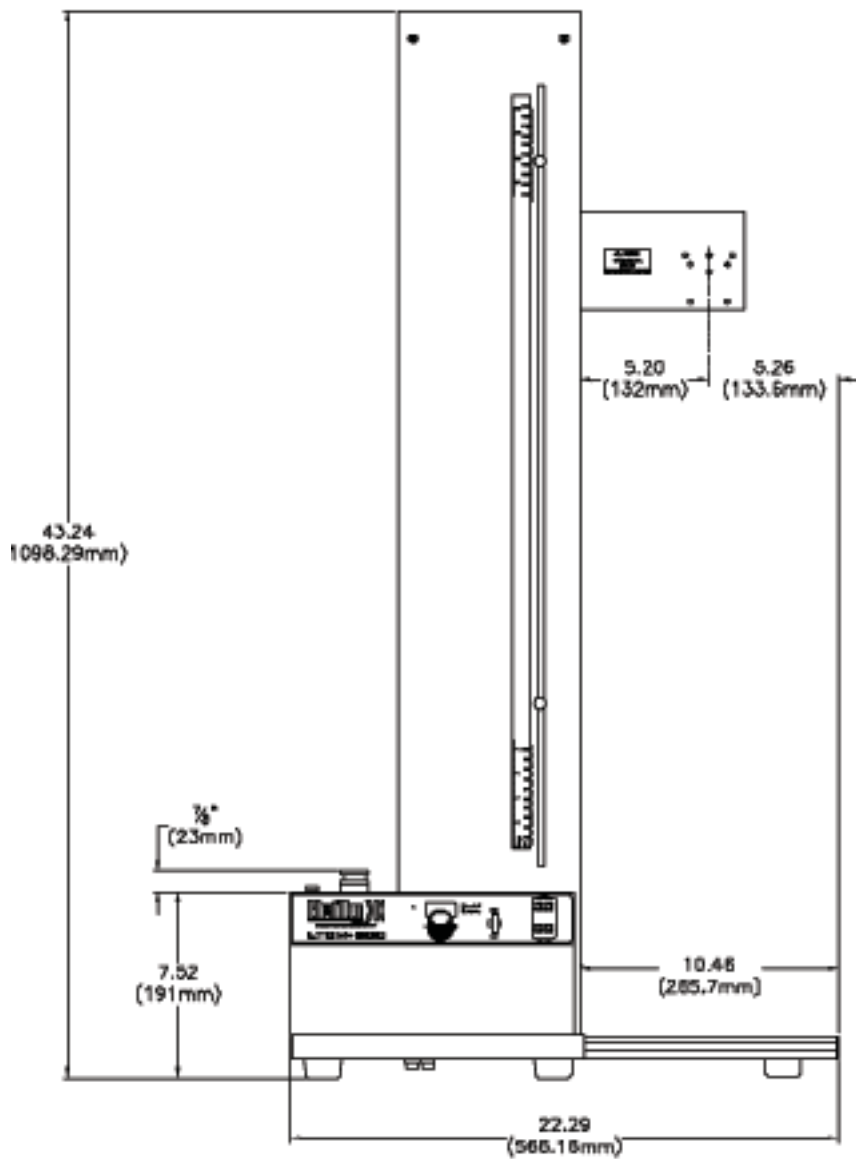
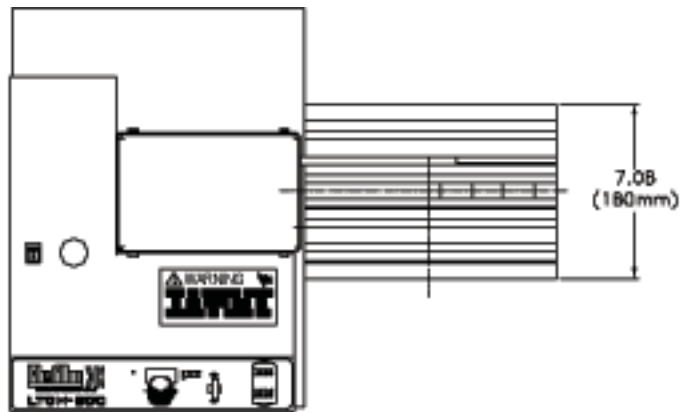

# Dimensions - LTCM-500 Series

## Expanded Work Table - SPK-LTCM-067

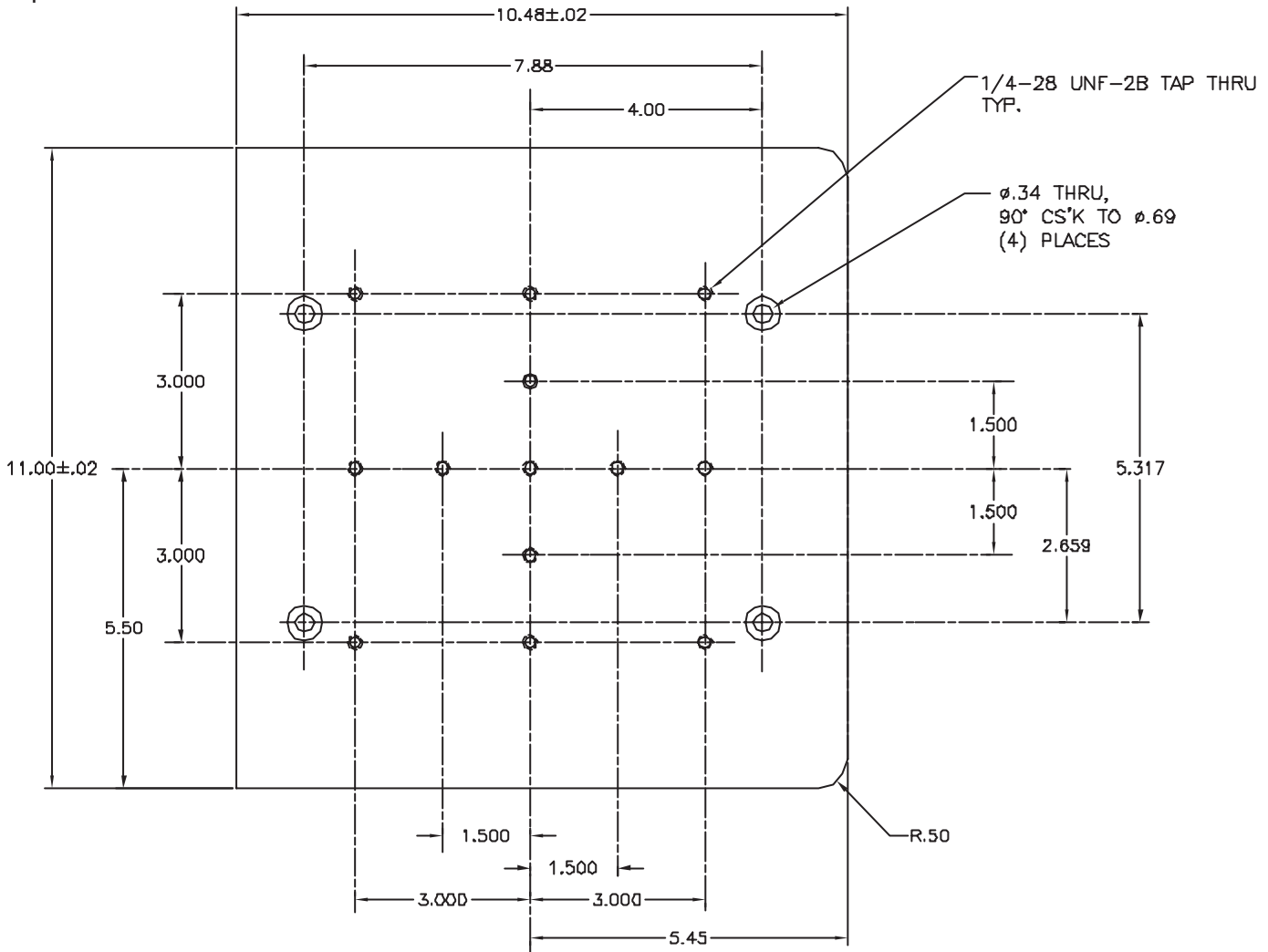

## Adapter, SLC Sensor - SPK-LTCM-066

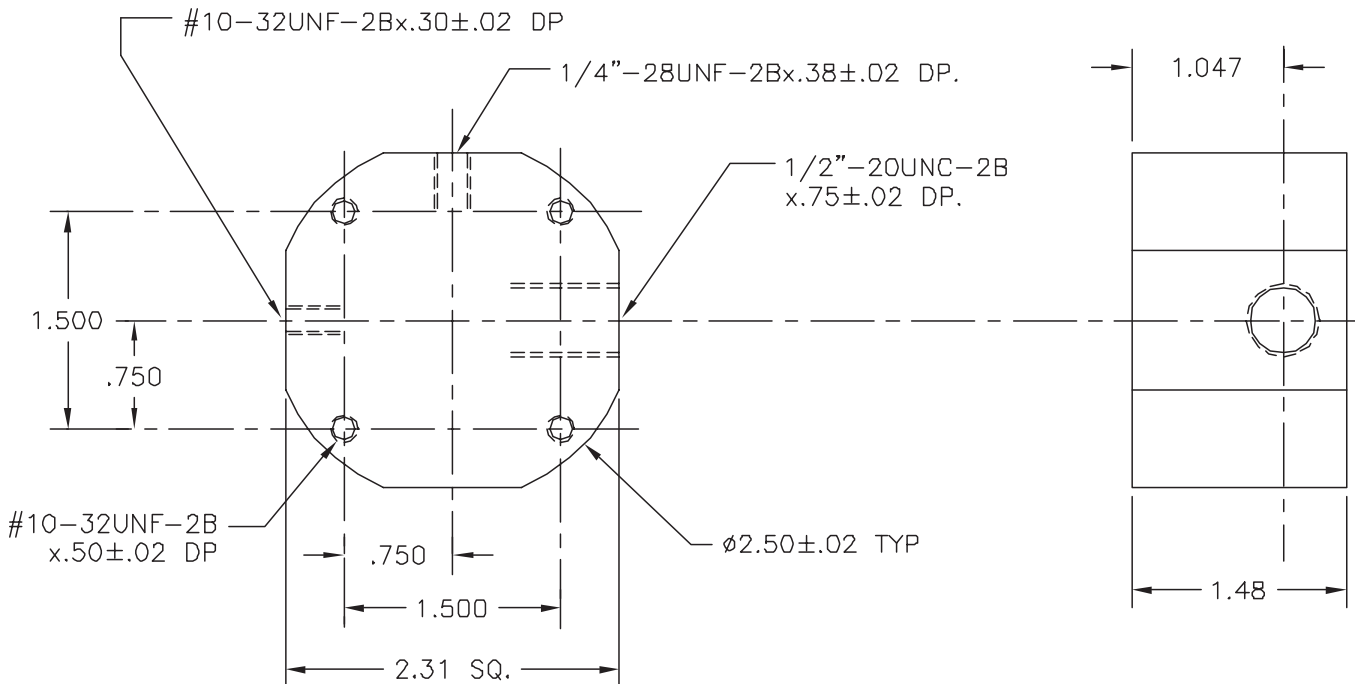

## Ordering Information

Model	Capacity	Description
LTCM-500	550 lbf (2500N)	LTCM-500, 115/230Vac, US Plug
LTCM-500-EU	550 lbf (2500N)	LTCM-500, 115/230Vac, EU Plug
LTCM-500-UK	550 lbf (2500N)	LTCM-500, 115/230Vac, UK Plug

### Standard Accessories

Part No.	Description
SPK-FMG-012C	Hook, Stationary (550 lbf, 2500N)
17012	Compression Plate, 3" (75mm)
NC002924	Hex Key, 5mm
NC000846	Hex Key, 5/32"
NC002905	Adapter Plate, DF Series Gauge
1613	Screws (4) #10-32 x 3/4
SPK-FM200-034	Power Cord, US Plug 115V
SPK-FM200-022	Power Cord, EU Plug 230V
SPK-LTCM-UK230	Power Cord, UK Plug 230V

### Optional Accessories

Part No.	Description
SPK-LTCM-067	Expanded Work Table
SPK-LTCM-066	Adapter, SLC Sensors
NC002910	Footswitch Controller
NC002927	Splinter Shield, Mechanical



### LTCM Series Testers

The LTCM Series testers include the LTCM-100 Series for load measurements up to 110 lbf (500N) and the LTCM-500 Series for load measurements up to 550 lbf (2500N). Both testers are compact, easy-to-use and adaptable for production, quality control or R&D applications. All LTCM Series testers have a 2-year warranty.



### Optional Mounting Table

The optional, expanded table mounts directly on top of the standard T-slot fixturing leg. This table includes pre-drilled 1/4-28 holes for mounting grips and fixtures for a variety of testing applications. The table is made of aluminum.



## US GAUGE DIVISION

Americas  
AMETEK US Gauge Division  
8600 Somerset Drive  
Largo, Florida 33773  
United States of America  
Tel +1-727-536-7831  
Tel +1-800-527-9999  
Fax +1-727-539-6882  
Email [chatillon.fl-lar@ametek.com](mailto:chatillon.fl-lar@ametek.com)

United Kingdom  
Lloyd Instruments Ltd.  
12 Barnes Wallis Road  
Segensworth East  
Fareham  
Hants, PO15 5TT  
United Kingdom  
Tel +44 (0) 1489 486 399  
Fax +44 (0) 1489 885 118  
Email [uk-far.general@ametek.co.uk](mailto:uk-far.general@ametek.co.uk)

France  
AMETEK S.A.S.  
Rond Point de l'Epine des Champs  
Buro Plus - Bat. D  
78990 Elancourt  
France  
Tel +33 (0)1 30 68 89 40  
Fax +33 (0)1 30 68 89 49  
Email [general@lloyd-instruments.com](mailto:general@lloyd-instruments.com)

Germany  
AMETEK GmbH  
Rudolf-Diesel-Strasse 16  
D-40670 Meerbusch  
Germany  
Tel +49 (0)2159 9136-70  
Fax +49 (0)2159 9136-39  
Email [info@ametek.de](mailto:info@ametek.de)

Singapore  
AMETEK Singapore Pvt. Ltd.  
10 Ang Mo Kio Street 65  
#05-12 Techpoint  
Singapore 569059  
Tel +65-484-2388  
Fax +65-481-6588  
Email [aspl@ametek.com.sg](mailto:aspl@ametek.com.sg)

Visit Us on the Worldwide Web at:  
[www.chatillon.com](http://www.chatillon.com)

© 2006 by AMETEK, Inc.

Information within this document is subject to change without notice.



ISO 9001/2000  
ISO/IEC 17025  
Manufacturer