

**Pressure Module (PM)**

**ACCURACY**

**bar (Gauge Pressure)**

**3, 10, and 30 bar modules**

0 to 30% of Range:  $\pm(0.0075\%$  of Full Scale)

30 to 110% of Range:  $\pm(0.025\%$  of Reading)

Vacuum:  $\pm(0.06\%$  of Full Scale\*, typical)

\* Full Scale = -1.0 bar

**100 and 300 bar modules**

0 to 30% of Range:  $\pm(0.015\%$  of Full Scale)

30 to 110% of Range:  $\pm(0.05\%$  of Reading)

**700 and 1000 bar modules**

0 to 30% of Range:  $\pm(0.03\%$  of Full Scale)

30 to 110% of Range:  $\pm(0.1\%$  of Reading)

*Includes all effects of linearity, hysteresis, repeatability, temperature, and stability for one year.*

*All models indicate vacuum, but vacuum specification (typical) applies to 3, 10, and 30 bar models only.*

*Not recommended for continuous use at high vacuum.*

*Refer to [XP2i-DP data sheet](#) for gauges that are intended for continuous high vacuum use.*

**barA (Pressure with BARO module)**

**3 bar module**

0.0138 to 1.0000 barA:  $\pm 0.0008$  barA, typical

1.0000 to 4.0000 barA:  $\pm(0.025\%$  of Reading)+0.0003 barA

**10 bar module**

0.0138 to 1.0000 barA:  $\pm 0.0008$  barA, typical

1.0000 to 4.0000 barA:  $\pm 0.0010$  barA

4.0000 to 11.0000 barA:  $\pm(0.025\%$  of Reading)

**30 bar module**

0.014 to 1.000 barA:  $\pm 0.001$  barA, typical

1.000 to 10.000 barA:  $\pm 0.003$  barA

10.000 to 31.000 barA:  $\pm(0.025\%$  of Reading)

**100 bar module**

1.000 to 31.000 barA:  $\pm 0.015$  barA

31.000 to 101.000 barA:  $\pm(0.05\%$  of Reading)

**300 bar module**

1.00 to 91.00 barA:  $\pm 0.05$  barA

91.00 to 301.00 barA:  $\pm(0.05\%$  of Reading)

**700 bar module**

1.00 to 211.00 barA:  $\pm 0.21$  barA

211.00 to 701.00 barA:  $\pm(0.1\%$  of Reading)

**1000 bar module**

1.00 to 301.00 barA:  $\pm 0.30$  barA

301.00 to 1001.00 barA:  $\pm(0.1\%$  of Reading)

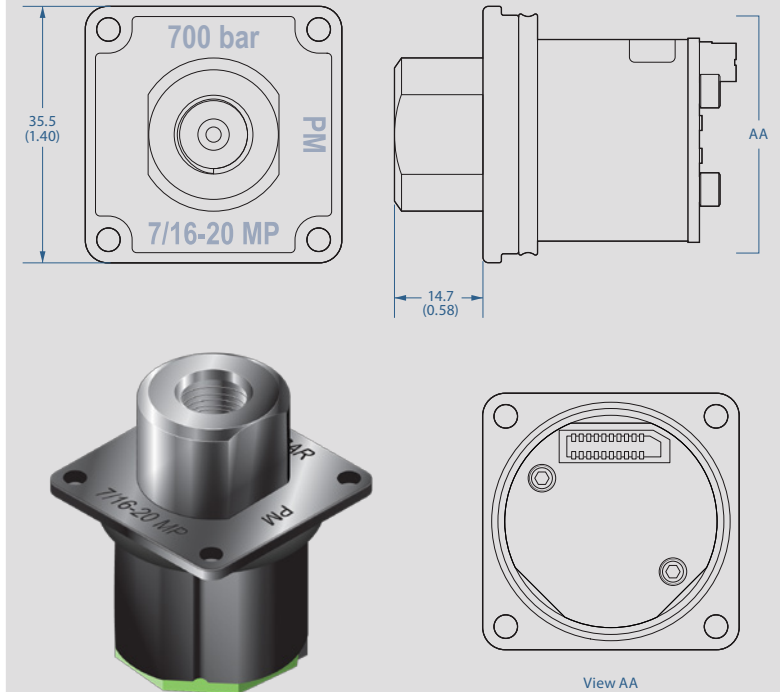

## DIFFERENTIAL PRESSURE MEASUREMENT UNCERTAINTIES WITH TARE

The Tare function can improve measurement uncertainties on two modules with the same full scale pressure range installed into one nVision Reference Recorder. Requires the use of an equalizing valve.

The following specifications apply to the measurement system with a logging interval of 1 second/reading:

Full Scale Range of Both Sensors bar	The Greater of (+/-)				or	% of DP Reading
	mbar	PSI	inH <sub>2</sub> O	mmH <sub>2</sub> O		
3	0.04	0.0005	0.014	0.4	or	0.025%
10	0.10	0.0015	0.04	1.0	or	0.025%
30	0.4	0.005	0.14	4.0	or	0.025%
100	1.0	0.02	0.4	10.0	or	0.05%
300	4.0	0.05	1.4	n/a	or	0.05%
700	10.0	0.2	4.0	n/a	or	0.1%
1000	15.0	0.3	6.0	n/a	or	0.1%

Unit must be enabled in CrystalControl

## DIFFERENTIAL PRESSURE MEASUREMENT UNCERTAINTIES WITHOUT TARE

The total nVision Reference Calibrator measurement uncertainty in the  $\Delta P$  mode configuration will need to consider the uncertainties of both pressure modules. We recommend the module uncertainties to be combined with the preferred square root of the sum of the squares (or “root sum squares”) method.

The following table lists the possible combinations of using Pressure Modules (PM) with different accuracy statements. The uncertainties reported below are without the use of the Tare feature, which will greatly improve your measurement uncertainty.

		Upper Pressure Module Uncertainties (of Static Line Pressure) (of Reading)		
		0.025%	0.05%	0.10%
Lower Pressure Module Uncertainties (of Static Line Pressure) (of Reading)	0.025%	0.035%	0.056%	0.103%
	0.05%	0.056%	0.071%	0.112%
	0.10%	0.103%	0.112%	0.141%

**SENSOR**

Wetted Materials: (WRENCH TIGHT) **316 stainless steel**  
(FINGER TIGHT) **316 stainless steel**  
**and Viton® (internal o-ring)**  
Diaphragm Seal Fluid: **Dow Corning® 200**  
Connection: **Crystal CPF Female**

*All welded, with a permanently filled diaphragm seal.*  
*Metal to metal cone seal; O-ring can be removed if necessary.*  
*1/4" medium pressure tube system compatible with HIP LM4 and LF4 Series, Autoclave Engr SF250CX Male and Female Series.*  
*CPF Adapters to NPT, BSP, and M20 available.*

**BAROMETRIC REFERENCE (BARO)**

Accuracy: **± 0.5 mbar, ± 0.00725 PSI**  
Range: **700.0 to 1100.0 mbarA,**  
**10.153 to 15.954 PSIA**  
Units and Resolution: **PSI ..... 0.001**  
**inHg ..... 0.001**  
**mmHg ..... 0.01**  
**mbar ..... 0.1**  
Pressure Connection: **Cylindrical sensor fitting of 5.8mm**  
**OD. A flexible 4.8 mm [3/16"] ID**  
**tube is recommended to connect for**  
**for calibration.**  
Mounting: **Secured using a 3/8" 4-40 plastic screw.**

*Includes all effects of linearity, hysteresis, repeatability, temperature, and stability for one year.*  
*Exposure to environmental extremes of temperature, shock, and/or vibration may warrant a more frequent recertification period.*  
*Other units available depending on the installed modules.*



## Current, Voltage, & Switch Test Module (MA20)

Intended for use with a 4-20mA loop measurement. This module is also capable of measuring supply voltages and has an auxiliary fixed output for use in switch open/closure testing. Each MA20 module includes a super flexible silicone test lead kit (P/N 3952).

### CURRENT & VOLTAGE MEASUREMENT

#### Current (mA) Input

Accuracy:  $\pm(0.015\% \text{ of rdg} + 0.002 \text{ mA})$

Range: **0 to 55 mA (MA20+)**  
**0 to 25 mA (MA20)**

Max Allowable Current: **93.3 mA**

Resolution: **0.001 mA or 0.01%**

Units: **mA, % 4-20, % 10-50**

Input Resistance: **< 17.2  $\Omega$**

Voltage Burden @ 20mA: **< 0.35 V**

Voltage Burden @ 50mA: **< 0.86 V**

HART Resistance: **250  $\Omega$**

Connection: **2mm jacks**

*Includes all effects of linearity, hysteresis, repeatability, temperature, and stability for one year.*

**WARNING:** ATEX and IECEx certification does not allow the installation of two MA20 modules.

*Inputs protected by a resettable fuse.*

*mA can be displayed as a percentage, where 0 to 100% corresponds to either 4 to 20 mA or 10 to 50 mA.*

*Jacks are compatible with safety sheathed banana plugs.*

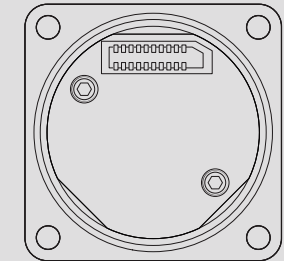
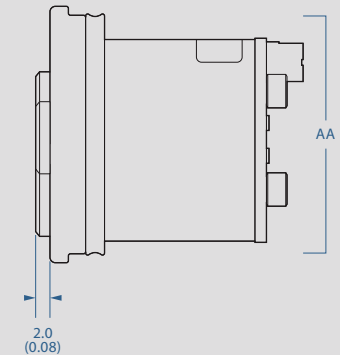
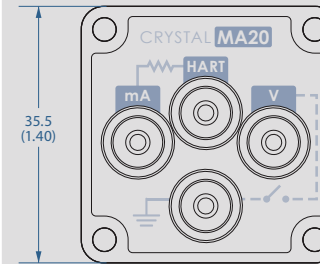

View AA

#### Voltage (VDC) Input

Accuracy:  $\pm(0.015\% \text{ of rdg} + 0.002 \text{ VDC})$

Range: **0 to 28 VDC**

Max Allowable Voltage: **30 VDC**

Resolution: **0.001 VDC**

Units: **VDC**

*Includes all effects of linearity, hysteresis, repeatability, temperature, and stability for one year.*

#### Switch Test

Switch Type: **Dry Contact**

Closed State Resistance: **< 10  $\Omega$**

Open State Resistance: **> 10 M $\Omega$**

*Switch state change indicated by bright green LED flash.*

*Switch test screen reports switch open, close, and deadband values.*

### ATEX and IECEx Scheme Entity Parameters

The MA20 Module has these specific input entity parameters:

<b>Ui = 28 V</b>	<b>Uo = 6.6 V</b>
<b>Ii = 93.3 mA</b>	<b>Io = 4.45 mA</b>
<b>Pi = 653.3 mW</b>	<b>Po = 7.34 mW</b>
<b>Ci = 0.36 <math>\mu</math>F</b>	<b>Co = 0.5 <math>\mu</math>F*</b>
<b>Li = 39.1 <math>\mu</math>H</b>	<b>Lo = 12 <math>\mu</math>H**</b>

\* Dependent on the supply to the terminals but shall not be greater than 0.5  $\mu$ F

\*\* Total cable inductance between all modules

**Temperature Module (RTD100)**

Calibrated for Pt100 RTD/PRT (100 Ohms at 0°C Platinum Resistance Temperature Detector) sensors conforming to DIN/ IEC 60751 (or IEC751) with US, Euro, or Lab calibration curves. An RTD is not included, but each RTD100 includes P/N 3953 RTD Connection Kit.

**TEMPERATURE MEASUREMENT**

**Resistance Input**

Accuracy:  $\pm (0.015\% \text{ of rdg} + 0.02 \Omega)$

Range: **0 – 400 Ohms range for use with 100 Ohm PRTs**

Resolution: **0.01 on all scales**

Units: °C, K, °F, R,  $\Omega$

TCRs: **0.003850  $\Omega/\Omega/^\circ\text{C}$  (IEC 60751), 0.003911  $\Omega/\Omega/^\circ\text{C}$  (US Industrial Std), 0.003926  $\Omega/\Omega/^\circ\text{C}$**

Wiring: **2-, 3-, 4-wire support**

Connection: **M8 connector cable or terminal block**

*Includes all effects of linearity, hysteresis, repeatability, temperature, and stability for one year.*

The proper selection of the RTD sensing element is very important as the error associated with this device is the majority of the overall system measurement uncertainty. IEC 751 is the standard that defines the temperature versus resistance for 100 $\Omega$ , 0.00385  $\Omega/\Omega/^\circ\text{C}$  platinum RTDs. IEC 751 defines two classes of RTDs: Class A and B. Class A RTDs operate over the -200 to 630 $^\circ\text{C}$  range versus -200 to 800 $^\circ\text{C}$  for the Class B elements. For example, the Class A uncertainty is about half that of the Class B elements as illustrated in the following table.

Temperature	nVision Uncertainty		Class A				Class B			
	$\pm\Omega$	$\pm^\circ\text{C}$	$\pm\Omega$	$\pm^\circ\text{C}$	$\pm\Omega$	$\pm^\circ\text{C}$	$\pm\Omega$	$\pm^\circ\text{C}$	$\pm\Omega$	$\pm^\circ\text{C}$
-200	0.02	0.05	0.24	0.55	0.24	0.55	0.56	1.30	0.56	1.30
0	0.04	0.09	0.06	0.15	0.07	0.17	0.12	0.30	0.12	0.31
200	0.05	0.13	0.2	0.55	0.21	0.56	0.48	1.30	0.48	1.31
400	0.06	0.17	0.33	0.95	0.33	0.96	0.79	2.30	0.79	2.31
600	0.07	0.21	0.43	1.35	0.44	1.37	1.06	3.30	1.06	3.31
800	0.08	0.25	0.52	1.75	0.53	1.77	1.28	4.30	1.28	4.31

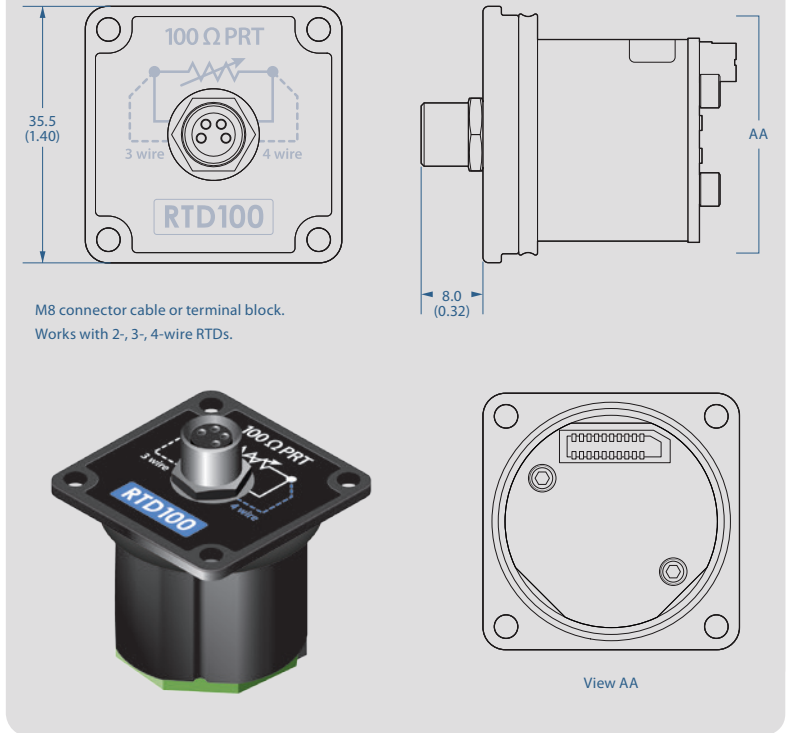

M8 connector cable or terminal block.  
Works with 2-, 3-, 4-wire RTDs.

View AA

**ATEX IECEx ATEX and IECEx Scheme Entity Parameters**

The RTD100 Module has these specific input entity parameters:

- U<sub>i</sub> = 0 V**
- U<sub>o</sub> = 9.73 V**
- I<sub>i</sub> = 0 A**
- I<sub>o</sub> = 1.6642 A**
- P<sub>i</sub> = 0 W**
- P<sub>o</sub> = 1.1 W**
- C<sub>o</sub> = 0.5  $\mu\text{F}$**
- L<sub>o</sub> = 12  $\mu\text{H}^*$**

\* Total cable inductance between all modules

**nVision Chassis (NV)**

**OPERATING TEMPERATURE**

Temperature Range: **-20 to 50° C (-4 to 122° F)**

< 95% RH, non-condensing. No change in accuracy over operating temperature range. Gauge must be zeroed to achieve rated specification.

Applies to all modules.

**DISPLAY**

Screen: **255 x 160 pixel graphical display**

LCD readable in sunlight with bright backlight.

Display Rate: **4 readings/second (standard)  
up to 10 readings/second (recording)**

**POWER**

4 x AA: **200 hours, typical**

Ultra Low Power: **Up to 60 days, typical\***

Approved Batteries: **The nVision is Intrinsically Safe only if powered by one of the following battery types:**

\*2 installed modules, 1 reading per 5 minute recording interval, and 23°C ambient temperature.

**WARNING:** Do not use the mini-USB serial interface in hazardous locations.

**WARNING:** Replace batteries with approved type in non-hazardous locations only.

Uses 4 alkaline AA (LR6) batteries. Use of backlight reduces operating time.

\*\*Energizer is manufactured by Energizer Holdings, Inc., and the Eveready Battery Company, Inc.

Approved Battery Type	Ta=	Marking
Rayovac Max Plus 815	-20 to 50° C	Ex ia IIB T4 Ga
Duracell MN1500	-20 to 45° C	
**Energizer E91, EN91	-20 to 50° C	Ex ia IIB T3 Ga
Duracell MN1500		

**DATA/COMMUNICATION**

Digital Interface: **mini-USB**

The mini USB will power the nVision with or without the battery pack installed.

**WARNING:** Do not use the mini-USB serial interface in hazardous locations.

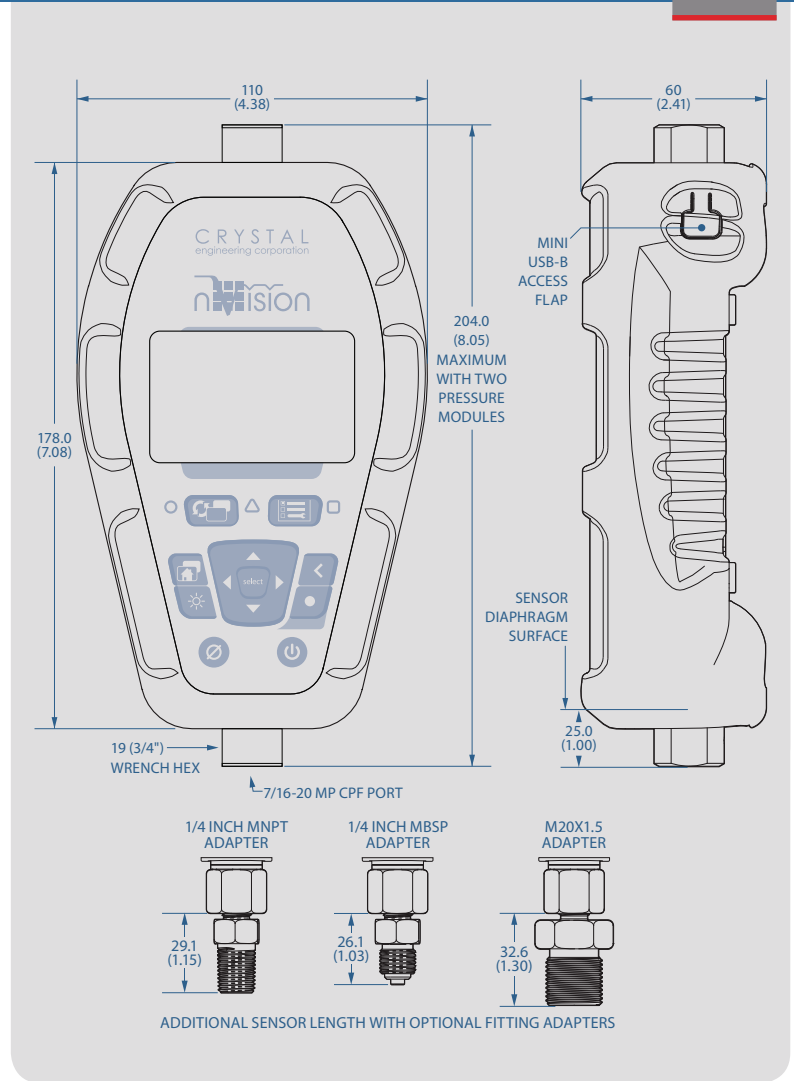

**DATALOGGING**

Capacity: **Approx. 1,000,000 data points\***

Storage Type: **Non-volatile flash memory**

Fastest Interval: **10 per second**

Slowest Interval: **1 per hour**

*\*Single Module Recording*

*The included CrystalControl software is compatible with 32 & 64 bit Windows 7 and Vista, and XP (32 bit only). Produces csv, xls, pdf, or signed pdf files, and uses Excel template files (samples included) to automatically format and graph data.*

**ENCLOSURE**

Weight: **680 g (24.0 oz)**

Rating: **IP67**

Housing: **Impact resistant injection molded**

Keypad and Labels: **UV Resistant Polyester**

Mounting: **M4 x 0.7 [8 mm (0.31")]** deep threaded insert mounting locations

*Weight includes one pressure module, one RTD module, 4AA battery module, and protective boot.*

*Submersible to 1 m for 30 minutes [IEC 60529].*

*LCD protected from impact damage by 1.5 mm (0.06") thick polycarbonate lens.*

*Skydrol® compatible.*

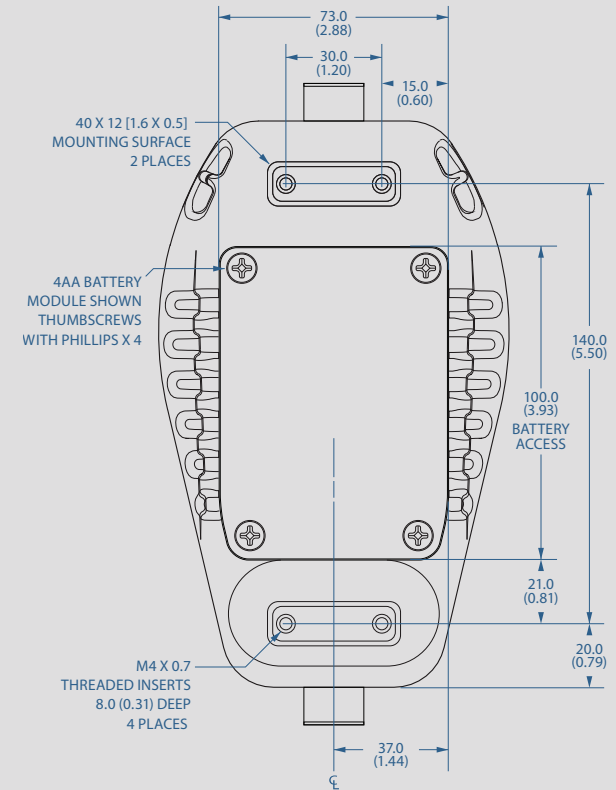

## STORAGE TEMPERATURE

Temperature Range: **-40 to 75° C (-40 to 167° F)**

*Batteries should be removed if stored for more than one month.*

## SPECIAL FEATURES

The following requires the use of our free [CrystalControl](#) software

Averaging Screen: **Averages all points in a recording run.**

Data Point Counter: **Screen for counting the data points logged.**

Display Screens: **Turn on and rearrange display screens.**

Estimated Recording Time: **A CrystalControl calculation based on active screens and logging interval.**

Live PC Graph: **During a recording, graph directly to your PC.**

Password Protect: **Changes to configuration or userspan calibration factor(s).**

Pressure Switch Test: **Using a PM and MA20, get deadband and state-change pressure.**

Remove: **Unwanted pressure units.**

Run Tags: **Create and enable run tags that will identify logging runs.**

Screen Numbers: **Number each display screen to make writing procedures around the nVision easier.**

Secure Documents: **Download into secure pdf documents for tamper proof records.**

Start-up Screen: **Define a 32-character prompt which requires user acknowledgement at startup.**

User Defined Unit: **Define and display any pressure units not included, or to use the gauge to display force, level or other pressure related parameters.**

## CERTIFICATIONS



**II 1G Ex ia IIB T4 Ga or T3**  
**SIRA 09ATEX2008X**

This product conforms to:

**EN 60079-0: 2006 | EN 60079-11: 2007 | EN 60079-26: 2007**



**Ex ia IIB T4 Ga or T3**  
**IECEx SIR09.0053X**

This product conforms to:

**IEC 60079-0: 2004 | IEC 60079-11: 2006 | IEC 60079-26: 2006**



nVision complies with the Electromagnetic Compatibility and the Pressure Equipment Directives. Refer to the EC Declaration of Conformity for specific details.



The instrument was tested against **AS/NZS 3584**, C-tick EMC/EMI requirements.



XP2i is approved for use as a portable test instrument for Marine use and complies with Det Norsjke Veritas' Rules for Classification of Ships, High Speed & Light Craft and Offshore Standards.



**RANGE & RESOLUTION TABLE**

PM	Range (bar)	Over-pressure	Display Resolution									
			bar	mbar	kPa	MPa	PSI	in H <sub>2</sub> O	in Hg	mm Hg	mm H <sub>2</sub> O	kg/cm <sup>2</sup>
3BAR	3	3.0 x	0.0001	0.1	0.01		0.001	0.01	0.001	0.01	1	0.0001
10BAR	10	2.0 x	0.0001	0.1	0.01	0.00001	0.001	0.1	0.01	0.1	1	0.0001
30BAR	30	2.0 x	0.001	1	0.1	0.0001	0.01	0.1	0.01	0.1		0.001
100BAR	100	2.0 x	0.001		0.1	0.0001	0.1		0.1			0.001
300BAR	300	1.5 x	0.01		1	0.001	0.1		0.1			0.01
700BAR	700	1.5 x	0.01		1	0.001	1					0.01
1KBAR	1000	1.3 x	0.01		1	0.001	1					0.01

Add one digit of resolution for differential mode.

**ORDERING INFORMATION**

Product ID	Power	Module: Upper	Module: Lower	BARO Module?
NV	4AA	_____	_____	_____
		<b>PM</b>	<b>PM</b>	No: (omit)
		<b>MA20</b>	<b>MA20</b>	Yes: <b>-BARO</b>
		<b>RTD100</b>	<b>RTD100</b>	
		<b>BNKPLT</b>	<b>BNKPLT</b>	

If ordering a nVision with only one module installed, please enter "BNKPLT" in the empty module slot.

**SAMPLE PART NUMBERS**

NV-4AA-**3BAR**-**300BAR**-**BARO** nVision with 3 bar pressure module (upper) and 300 bar pressure module (lower) with BARO module option

NV-4AA-**RTD100**-**700BAR** nVision with RTD100 temperature module (upper) and 700 bar pressure module (lower)

\* BAR versions available in USA direct from factory, only.

**ACCESSORIES (Included with NV)**

**Soft Carrying Case P/N 4087**

Durable, padded case with separate pockets for your nVision and accessories.

**Protective Boot P/N 3985**

Shock resistant protection, low durometer, Skydrol resistant.

**Mini-USB Cable P/N 3951**

Connect to your nVision with 6' [1.8m] cable.

**COMPLIMENTARY PRODUCTS**

**Crystal Engineering offers a wide range of products that work with the nVision:**

- [Fittings that connect without tools, safely and without leaks](#)
- [Lightweight, super flexible high pressure hoses](#)
- [Fitting kits and adapters](#)
- [Pneumatic hand pumps](#)
- [Hydraulic hand pumps](#)
- [Portable pressure comparators](#)
- [Software, for the quickest way to calibrate pressure transmitters and gauges](#)

Dow Corning is a registered trademark of Dow Corning Corporation.