

JOFRA™

Wide temperature range

-150 to 650°C (-238 to 1202°F)

A single sensor may cover the complete temperature range

Fast response time

Ensures correct monitoring of temperature stability in liquid baths or dry-block calibrators

Specified low drift

Maintains a minimal uncertainty budget over the entire period between re-calibration intervals. Allows for easier re-calibration scheduling

90° angled sensor

Allows the user to have both the sensor-under-test and the reference sensor in the dry-block at the same time

Calibration certificate

Wide choice of accredited or traceable certificates

JOFRA STS series

Superiour Temperature reference Sensors

PRODUCT DESCRIPTION

JOFRA STS Superior Temperature reference Sensors are a series of high quality reference sensors. Ideal for industrial temperature calibration applications where accuracy and long-term stability are important.

JOFRA STS Superior Temperature reference

Sensors are based on more than 50 years of industrial temperature sensor manufacturing experience.



Features

The main requirement of a reference sensor is stability: The less the sensor drifts, the lower the measurement uncertainty. All JOFRA Superior Temperature Standard sensors are economical and offer fast response times, low immersion depths, compact physical sizes, and specified low drift rates: even at high temperatures. These are all important considerations when selecting a reference sensor.

In addition to straight sensors, AMETEK offers a 90° angled version specifically developed for use with dry-block temperature calibrators. This sensor allows the user to have both the sensor-under-test and the reference sensor in the thermowell at the same time: even if the sensors have a connection or a transmitter head.

AMETEK has also designed a special cable type reference sensor permitting the sensor to be positioned throughout the depth of the well in a dry-block, eg. under a sanitary flange.

Epecially for the DTI050 reference indicator, AMETEK has developed a specific series of interlligent reference sensors.

JOFRA STS-050

Measuring temperature with intelligent sensors

The STS-050 reference sensors uses intelligent detection technology. This means that it is able to automatically read calibration data and sensor type from a memory chip placed in the sensor. This chip is standard in the STS-050 series.

The intelligent sensor reading makes it possible to change the sensors used without re-programming the DTI050. When an intelligent sensor is connected, all information about the sensor, such as serial number, calibration data and coefficients are read by DTI050. All information can be shown on the display in the config menu for verification. Recalling existing data eliminates errors as a result of programming sensor data.

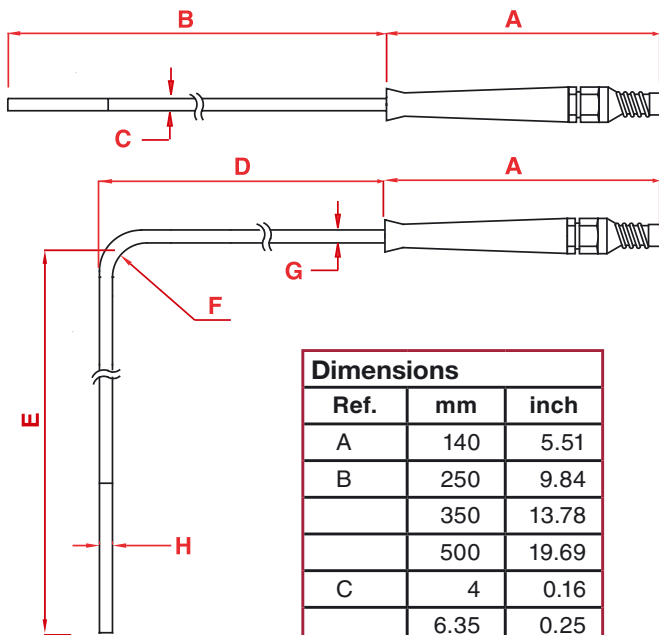

Dimensions		
Ref.	mm	inch
A	140	5.51
B	250	9.84
	350	13.78
	500	19.69
	6.35	0.25
C	4	0.16
D	100	3.93
	200	7.87
F	12	0.47
G	6.35	0.25
H	6.35	0.25

SPECIFICATIONS STS-050 A / B

Temperature range

All sensors.....-50 to 400°C / -58 to 752°F

Accuracy

Hysteresis¹⁾ @0°C / 32°F.....0.01°C / 0.02°F
 Long term stability ²⁾ @0°C / 32°F..... typ. 0.014°C / 0.025°F
 Repeatability ¹⁾..... 0.005°C / 0.009°F

- 1) when used in the range -50 to 400°C / -58 to 752°F.
 2) when exposed to 400°C / 752°F for 100 h. Stability will depend on actual use of the sensor.

Sensing element

Type.....Pt100
 Nominal resistance@0°C / 32°F..... 100 Ω
 Length 22 mm / 0.9 in
 Temperature coefficient $\alpha_{100}=0.00385$ 1/°C

Minimum immersion depth

STS-050 A (4 mm / 0.16 in): 60 mm / 2.36 in
 STS-050 B (6.35 mm / 0.25 in):..... 90 mm / 3.54 in

Self-heating effect

0.04°C/mW / 0.07°F/mW

Response time

STS-050 A (4 mm / 0.16 in): $\tau_{0.5}$ (50%)7 seconds
 STS-050 A (4 mm / 0.16 in): $\tau_{0.9}$ (90%) 17 seconds
 STS-050 B (6.35 mm / 0.25 in): $\tau_{0.5}$ (50%) 11 seconds
 STS-050 B (6.35 mm / 0.25 in): $\tau_{0.9}$ (90%)30 seconds

Liquid in motion $v=0.4$ m/s.

Electrical connections

Cable4 wire
 Connection..... REDEL goldplated

Insulation resistance

@ 23°C / 73°F 100 Gohm
 @ 400°C / 752°F 70 Mohm

Outer tube

AISI 316

Operating conditions

Sensor, connection, and cable.....Max. 70°C / 158°F
 Storage temperature -20 to 70°C / -4 to 158°F
 Humidity0 to 90% RH
 Protection class..... DIN 40050 IP-50

ORDERING JOFRA STS-050

Order no.	Description
STS050	Pt100 reference sensor, solid, with handle, -50 to 400°C / -58 to 752°F
Diameter of the sensor	
A	Overall diameter 4 mm (0.16 in)
B	Overall diameter 6.35 mm (0.25 in)
Shape and length	
250	Straight sensor, 250 mm (9.8 in) in carton
350	Straight sensor, 350 mm (13.8 in) in carton
500	Straight sensor, 500 mm (19.7 in) in carton
901	90° angled sensor, 207 mm (8.1 in) (only version B with Ø6.35 mm)
Cable length and termination	
D	Cable 1 m (3.3 ft.) + REDEL connector for DTI050
Calibration certificate	
F	NPL traceable calibration certificate (standard)
H	DANAK Accredited calibration certificate (opt.)
STS050A250DF	Sample order number 4 mm STS-050 Reference sensor, Straight 250 mm, Cable length 1 m (3.3 ft.) with REDEL connector for DTI050 and NPL traceable calibration certificate

STANDARD DELIVERY

- JOFRA STS-050 A/B sensor with handle
- 90° angled sensor, delivered in carton box
- Straight sensors, delivered in carton box
- Traceable calibration certificate, 6 points from -45 to 400°C
- Cable - according to order number
- User manual

COMPATIBLE JOFRA INSTRUMENTS

The JOFRA STS-050 sensor is designed for fast and traceable calibration and temperature measuring with the following JOFRA calibrators:

- JOFRA DTI050 + STS-050

Find the product specification sheets at www.jofra.com



JOFRA STS-100 A/B

Quality defined

It is not easy to make a good quality reference sensor. The main requirement of a reference sensor is stability. This means minimal drift as a function of operating time at the actual temperature. The less the sensor drifts, the lower the measurement uncertainty.

Small diameter - fast response

The STS-100 A/B series has a relatively small diameter (STS-100 A: 4 mm / 0.16 in and STS-100 B: 6.35 mm / 0.25 in.) This leaves optimum space for sensors-under-test in the dry-block and ensures a fast response time. A fast reacting sensor will optimize the measurement information.

Reduced hysteresis and drift

The sensing element is comprised of a pure platinum coil. This coil is suspended in a way that minimizes stress and ensures a near zero hysteresis value.

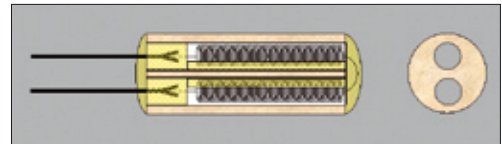

The main reason for drift within a sensor assembly is impurities within the element, especially at temperatures above 350°C (660°F). All internal parts must be cleaned thoroughly. AMETEK has developed a unique cleaning method for the internal bore of the Inconel® sheath. The platinum sensor is embedded within an ultra-clean, temperature resistant ceramic, and assembly of the components is performed in a clean room. These precautions ensure minimum contamination of the element during use and provide the user with the best possible performance.

Ageing/annealing

Once the sensors are assembled, they are subjected to a long approval process. This includes mechanical stress reduction of the entire assembly as well as ageing the sensor element itself. The purpose of ageing the sensor is to remove the initial drift.

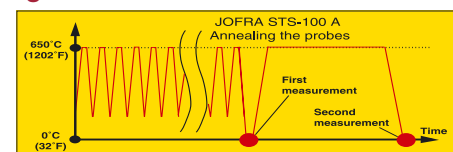

The procedure involves heating the sensor up to 650°C (1202°F) and holding it for 1 hour before cooling down. This process is repeated over a period of several days. The resistance is then measured at 0°C (32°F) and recorded. The sensor is again heated up to 650°C (1202°F), and this time the temperature is held constant for 100 hours.

Finally, the output from the sensor is again measured at 0°C (32°F) and recorded. The difference between the first and the second measurement is recorded. The difference between these two measurements is our verification of the stability qualities of the sensor. To be accepted for final calibration and certification, the sensor must meet our minimum tolerance, which we document in a quality certificate.

Reduced isolation-resistance-error

Electrical isolation resistance (parasite-resistance-error), when measured at the highest operating temperature, should be as high as possible. A low isolation resistance would cause the output signal to be incorrect in relation to the temperature. JOFRA STS-100 A/B series sensors meet the IEC-751 requirements of isolation resistance by several hundred percent.

The final quality-certificate-check

Upon completion of every certificate, after final calibration of the sensor, examination and approval cycles are performed according to our established procedures. The critical verification is to ensure that the difference between the initial and the final 0°C (32°F) measurement on the certificate meets our minimum tolerance. These requirements are based on a vast amount of data, which has been evaluated statistically. This value indicates if the sensor has a sufficient long-term stability. AMETEK also checks that the linearization coefficients have values that correlate to an acceptable curve sequence in accordance with our requirements.

Certification

The final documentation on the sensor is the calibration certificate. The JOFRA STS-100 A/B sensors have the following calibration options:

Accredited certificate (standard):

(Traceable to the European Accreditation Organisation)
Temperature range from -90 to 650°C (-130 to 1202°F).

The certificate contains min. 6 temperature points starting and ending at 0°C (32°F). The certificate also contains calculated linearization coefficients .

The entire temperature calibration uncertainty:

-90 to 125°C (-130 to 257°F): ±0.03°C (±0.054°F)
-45 to 250°C (-49 to 482°F): ±0.02°C (±0.036°F)
250 to 320°C (482 to 608°F): ±0.03°C (±0.054°F)
320 to 650°C (608 to 1202°F): ±0.05°C (±0.090°F)

Traceable certificate (optional):

Temperature range from -90 to 650°C (-130 to 1202°F).

The certificate contains min. 6 temperature points starting and ending at 0°C (32°F). The certificate also contains calculated linearization coefficients .

Calibration uncertainty:

-90 to 125°C (-130 to 257°F): ±0.03°C (±0.054°F)
-45 to 155°C (-49 to 311°F) ±0.05°C (±0.090°F)
-45 to 650°C (-49 to 1202°F) ±0.05°C (±0.090°F)
33 to 320°C (91 to 608°F) ±0.05°C (±0.090°F)
33 to 650°C (91 to 1202°F) ±0.05°C (±0.090°F)

Delivery without certificate (annealed only) - (optional):

In some cases, the customer may prefer to calibrate the sensor. It is possible to purchase the sensor without any certification. AMETEK does not recommend this option because we are not able to complete the final "quality-certificate-check".

Custom-made certificate (optional):

The traceable certificate and the accredited certificates may both be customized to meet customer requirements; extra calibration points, different temperature points, limited or extended temperature ranges are available.

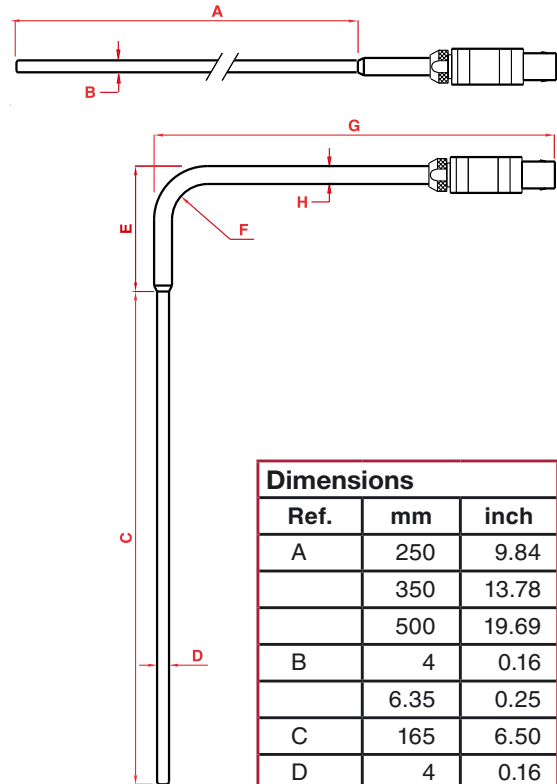

Dimensions		
Ref.	mm	inch
A	250	9.84
	350	13.78
	500	19.69
B	4	0.16
	6.35	0.25
C	165	6.50
D	4	0.16
	6.35	0.25
E	42	1.65
F	12	0.47
G	134	5.28
H	6	0.24



COMPATIBLE JOFRA INSTRUMENTS

The JOFRA STS-100 sensor is designed for fast and traceable calibration and temperature measuring with the following JOFRA calibrators:

- JOFRA DTI-1000
- JOFRA DTI050
- JOFRA ATC series
- JOFRA ASC300
- JOFRA AMC910

Find the product specification sheets at www.jofra.com

SPECIFICATIONS STS-100 A/B

Temperature range

All sensors..... -150 to 650°C / -238 to 1202°F

Accuracy

Hysteresis¹⁾ @0°C / 32°F.....0.01°C / 0.02°F
Long term stability ²⁾ @0°C / 32°F..... typ. 0.014°C / 0.025°F
Repeatability ¹⁾..... 0.002°C / 0.0036°F

Note 1: When used in the range -90 to 650°C / -130 to 1202°F.

Note 2: When exposed to 650°C / 1202°F for 100 h. Stability will depend on actual use of the sensor.

Sensing element

Type.....Pt100
Nominal resistance@0°C / 32°F.....100 Ω
Length40 mm / 1.6 in
Temperature coefficient $\alpha_{100}=0.00385$ 1/°C

Minimum immersion depth

STS-100 A (4 mm / 0.16 in): 100 mm / 3.9 in
STS-100 B (6.35 mm / 0.25 in): 110 mm / 4.3 in

Self-heating effect

0.06°C/mW / 0.108°F/mW

Response time

STS-100 A (4 mm / 0.16 in): $\tau_{0.5}$ (50%).....8 seconds
STS-100 A (4 mm / 0.16 in): $\tau_{0.9}$ (90%).....26 seconds
STS-100 B (6.35 mm / 0.25 in): $\tau_{0.5}$ (50%).....18 seconds
STS-100 B (6.35 mm / 0.25 in): $\tau_{0.9}$ (90%).....44 seconds

Liquid in motion $v=0.4$ m/s.

Electrical connections

Cable4 wire + shield
Connection..... LEMO goldplated

Insulation resistance

@ 23°C / 73°F..... 100 Gohm
@ 650°C / 1202°F..... 70 Mohm

Outer tube

Inconel 600

Operating conditions

Sensor connection and cableMax. 70°C / 158°F
Storage temperature -20 to 70°C / -4 to 158°F
Humidity0 to 90% RH
Protection class (connectors) DIN 40050 IP-50

Shipping dimensions - including carrying case

Straight sensors, L x W x H.....
..... 750 x 140 x 140 mm / 29.5 x 5.5 x 5.5 in
90° angled sensor, L x W x H.....
..... 220 x 250 x 60 mm / 8.7 x 9.8 x 2.4 in

Shipping weight including packing

Straight sensors 1.9 kg / 4.2 lb
90° angled sensor 550 g / 1.2 lb

ORDERING JOFRA STS-100 A/B

Order no.	Description
STS100	Base model number Pt100 reference sensor, solid, -150 to 650°C / -238 to 1207°F
Diameter of the sensor	
A	Overall diameter 4 mm (0.16 in)
B	Overall diameter 6.35 mm (0.25 in)
Shape and length	
250	Straight sensor, 250 mm (9.8 in) in alu case
350	Straight sensor, 350 mm (13.8 in) in alu case
500	Straight sensor, 500 mm (19.7 in) in alu case
901	90° angled sensor, 207 mm (8.1 in) in plastic case
Cable length and termination	
A	Cable 0.5 m (1.6 ft.) + LEMO connector
B	Cable 2 m (6.6 ft.) + LEMO connector
C	Cable 2 m (6.6 ft.) + Banana plug connectors
D	Cable 2 m (6.6 ft.) + REDEL connector for DTI050
Calibration certificate	
H	DANAK Accredited Calibration Certificate ¹⁾
HL	DANAK Accredited Calibration Certificate ²⁾
F	NPL Traceable Calibration Certificate ¹⁾
FL	NPL Traceable Calibration Certificate ²⁾
G	NIST Traceable Calibration Certificate ¹⁾
I	No certificate - Annealed only (Useless without calibration certificate / co-efficients)

STS100A901DH Sample order number

4 mm STS-100 Reference sensor angled
90°, Cable length 2 m (6.6 ft.) with REDEL
connector for DTI050 and accredited
calibration certificate.

Notes about calibration certificates:

- 1) Temperature range from -45°C to 650°C
- 2) Temperature range from -90°C to 125°C

STANDARD DELIVERY

- STS-100 A/B sensor
- 90° angled sensor, delivered in plastic case
- Straight sensors, delivered in alu case
- Traceable calibration certificate,
6 points from -45 to 650°C
- Cable - according to order number
- User manual

ACCESSORIES

122801	Cable 0.5 m (1.6 ft.) LEMO to LEMO
65-PT100-LL-CABLE	Cable 2 m (6.6 ft.) + LEMO to LEMO
65-PT100-LB-CABLE	Cable 2 m (6.6 ft.) + LEMO to banana
125522	Cable 2 m (6.6 ft.) with LEMO / Redel for DTI050

JOFRA STS-102 A

JOFRA has also designed a special cable type reference sensor, the STS-102 A. Due to the small size and flexible connection, the design permits positioning of the sensor throughout the depth of the well in a dry-block, eg. under a sanitary flange.

The reference sensor must be placed at the same level and in parallel with the sensor-under-test as indicated in the illustration to the right. The illustration shows calibration of a sanitary sensor. The sensor is in contact with the insert.

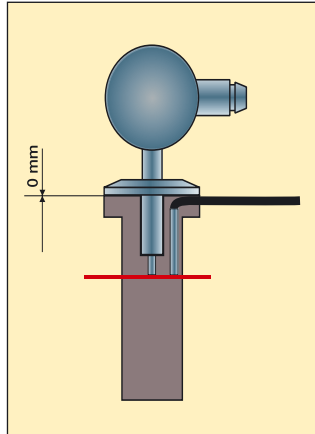

Below you see the custom insert and STS-102 A reference sensor placed in a JOFRA ATC-156 B dry-block calibrator. On the right, the sanitary sensor has been fitted into the insert and is ready for calibration. Note that the design makes room for the reference sensor cable.



To learn more about the possibilities with the JOFRA STS-102 A reference sensor, please see accessory sheet AS-CP-2201 at www.jofra.com

ACCESSORIES

Complete application kit for calibration of sanitary sensors in ATC-156 B

Including:
STS102A030SH,
Recalibration Tube,
Manual, 5-Pack
Undrilled Insertion
Tubes with Cable
Groove, Carrying
Case

Order no.: 123859



SPECIFICATIONS STS-102 A

Temperature range

All sensors.....-50 to 155°C / -58 to 311°F

Accuracy

Hysteresis @0°C / 32°F 0.01°C / 0.018°F
Long term stability 1) @0°C / 32°F ...typ. 0.025°C / 0.045°F
Repeatability 0.002°C / 0.0036°F

Note 1: When exposed to 155°C (311°F) for 200 hours. stability will depend on actual use of the sensor.

Sensing element

Type..... Pt100
Nominal resistance@0°C / 32°F 100Ω
Length 30 mm / 1.18 in
Temperature coefficient $\alpha_{100}=0.00385$ 1/°C

Minimum immersion depth

30 mm / 1.18 in

Self-heating effect

0.06°C/mW / 0.108°F/mW)

Response time

$\tau_{0.9}$ (90%) 16 seconds

Measured in water

Electrical connections

Cable 4 wire + shield
Connection LEMO goldplated

Insulation resistance

@ 23°C / 73°F 3 Gohm

Outer tube

AISI 316TI

Operating conditions

Sensor connection Max. 70°C / 158°F
Sensor cable Max. 175°C / 347°F
Storage temperature -20 to 70°C / -4 to 158°
Humidity 0 to 90% RH
Protection class (connectors) DIN 40050 IP-50

Shipping dimensions

STS-102 A sensor (including carrying case):
L x W x H..... 220 x 250 x 60 mm / 8.7 x 9.8 x 2.4 in
Shipping weight including packing
STS-102 A sensor 550 g / 1.2 lb



ORDERING JOFRA STS-102 A

Order no.	Description
STS102	Base model number Pt100 reference sensor, cable, -50 to 155°C (-58 to 311°F)
A	Diameter of the sensor Overall diameter 4 mm (0.16 in)
030	Shape and length Short sensor 30 mm (1.18 in) in plastic case
S	Cable length and termination Cable 1 m (3.3 ft.), Integrated Teflon cable, LEMO connector
D	Cable 1 m (3.3 ft.) + REDEL connector for DTI050
H	Calibration certificate Accredited calibration certificate (standard)
F	NPL traceable calibration certificate
G	NIST Traceable Calibration Certificate
I	No certificate - Annealed only (Useless without calibration certificate / co-efficients)

STS102A030DH Sample order number
4 mm STS-102, short 30 mm reference
sensor, Cable length 1 m (3.3 ft.) with
REDEL connector for DTI050 and accredited
calibration certificate.

STANDARD DELIVERY

- JOFRA STS-102 A sensor
- Sensor delivered in plastic case
- Traceable calibration certificate,
6 points from -45 to 155°C
- Cable - according to order number
- User manual
- Calibration tube

COMPATIBLE JOFRA INSTRUMENTS

The JOFRA STS-102 A 030 sensor is designed for fast
and traceable calibration and temperature measuring with
the following JOFRA calibrators:

- JOFRA DTI-1000
- JOFRA DTI050
- JOFRA ATC series
- JOFRA ASC300
- JOFRA AMC910

Find the product specification sheets at www.jofra.com

JOFRA STS-103

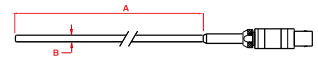

JOFRA has designed a spe-
cial 3 mm STS reference sen-
sor especially for the ETC-400
R calibrator. The sensor can
be used as a reference sen-
sor when a higher accuracy
is required or for recalibration of the ETC-400 R. Due to the
small immersion depth requirement of the sensor it can be
placed under the surface of the target.

Dimensions		
Ref.	mm	inch
A	150	5.91
B	3	0.12

SPECIFICATIONS STS-103

Temperature range

All sensors.....-50 to 400°C / -58 to 752°F

Accuracy

Hysteresis¹⁾ @0°C / 32°F.....0.01°C / 0.02°F
Long term stability ²⁾ @0°C / 32°F.....typ. 0.014°C / 0.025°F
Repeatability ¹⁾..... 0.005°C / 0.009°F

Note 1: When used in the range -45 to 400°C / -49 to 752°F.

Note 2: When exposed to 400°C / 752°F for 100 h. Stability will depend on
actual use of the sensor.

Sensing element

Type.....Pt100
Nominal resistance@0°C / 32°F.....100 Ω
Length 6 mm / 0.2 in
Temperature coefficient $\alpha_{100}=0.00385$ 1/°C

Minimum immersion depth

STS-103 B (3 mm / 0.12 in):40 mm / 1.6 in

Self-heating effect

0.06°C/mW / 0.108°F/mW

Response time

$\tau_{0.5}$ (50%).....5 seconds
 $\tau_{0.9}$ (90%).....15 seconds

Liquid in motion $v=0.4$ m/s.

Electrical connections

Cable 4 wire + shield
Connection LEMO goldplated

Insulation resistance

@ 23°C / 73°F 100 Gohm
@ 400°C / 752°F 70 Mohm

Outer tube

Inconel 600

Operating conditions

(Sensor, connection, and cable)Max. 70°C / 158°F
Storage temperature -20 to 70°C / -4 to 158°F
Humidity0 to 90% RH
Protection class (connectors) DIN 40050 IP-50

Shipping dimensions - including carrying case

L x W x H..... 750 x 140 x 140 mm / 29.5 x 5.5 x 5.5 in

Shipping weight including packing

STS-103 B2 kg / 4.4 lb

ORDERING INFORMATION STS-103 B

Order no.	Description
STS103	Pt100 reference sensor, -50°C to 400°C
Diameter of the sensor	
B	Overall diameter 3 mm
Shape and length	
150	Straight sensor, 150 mm (5.9 in)
Cable length and termination	
A	Cable 0.5 m (1.6 ft.) + LEMO connector
B	Cable 2 m (6.6 ft.) + LEMO connector
C	Cable 2 m (6.6 ft.) + Banana plug connectors
D	Cable 2 m (6.6 ft.) + REDEL connector for DTI050
Calibration certificate	
H	Accredited calibration certificate (standard)
F	NPL traceable calibration certificate
G	NIST traceable calibration certificate
I	No certificate - Annealed only (Useless without calibration certificate / co-efficients)
S	Special calibration certificate

STS103B150AH Sample order number
Reference Pt100 150 mm., cable length 0.5 m (1.6 ft.)
with LEMO termination and accredited certificate

STANDARD DELIVERY

- JOFRA STS-103 B sensor
- Sensor delivered in alu case
- Accredited calibration certificate, 6 points from -45 to 400°C
- Cable - according to order number
- User manual

ACCESSORIES

122801	Cable 0.5 m (1.6 ft.) LEMO to LEMO
65-PT100-LL-CABLE	Cable 2 m (6.6 ft.) + LEMO to LEMO
65-PT100-LB-CABLE	Cable 2 m (6.6 ft.) + LEMO to banana
125522	Cable 2 m (6.6 ft.) with LEMO / Redel for DTI050

COMPATIBLE JOFRA INSTRUMENTS

The JOFRA STS-103 sensor is designed for fast and traceable calibration and temperature measuring with the following JOFRA calibrators:

- JOFRA DTI-1000
- JOFRA ETC series
- JOFRA DTI050
- JOFRA ASC300
- JOFRA ATC series
- JOFRA AMC910

Find the product specification sheets at www.jofra.com

AMETEK[®]
CALIBRATION INSTRUMENTS

Headquarters:

AMETEK Denmark A/S
Gydevang 32-34 • 3450 Allerød • Denmark
Tel: +45 4816 8000 • ametek@ametek.dk

Sales & Service:

Europe, Asia, Africa, Middle East and South America

Information in this document is subject to change without notice.
©2007, by AMETEK, Inc., www.ametek.com. All rights reserved.

Pub code AS-CP-2210-US Issue 0901



AMETEK Calibration Instruments
is one of the world's leading manufacturers and developers of calibration instruments for temperature, pressure and process signals as well as for temperature sensors both from a commercial and a technological point of view.

JOFRA Temperature Instruments
Portable precision thermometers. Dry-block and liquid bath calibrators: 4 series, with more than 25 models and temperature ranges from -90° to 1205°C / -130° to 2200°F. All featuring speed, portability, accuracy and advanced documenting functions with JOFRACAL calibration software.

JOFRA Pressure Instruments
Convenient electronic systems ranging from -1 to 1000 bar (25 inHg to 14,500 psi) - multiple choices of pressure ranges, pumps and accuracies, fully temperature-compensated for problem-free and accurate field use.

JOFRA Signal Instruments
Process signal measurement and simulation for easy control loop calibration and measurement tasks - from handheld field instruments to laboratory reference level bench top instruments.

JOFRA / JF Marine Instruments
A complete range of calibration equipment for temperature, pressure and signal, approved for marine use.

FP Temperature Sensors
A complete range of temperature sensors for industrial and marine use.

M&G Pressure Testers
Pneumatic floating-ball or hydraulic piston dead weight testers with accuracies to 0.015% of reading.

M&G Pumps
Pressure generators from small pneumatic "bicycle" style pumps to hydraulic pumps generating up to 1,000 bar (15,000 psi).

*...because calibration is
a matter of confidence*

www.ametekcalibration.com
www.jofra.com

Sales & Service Offices:

AMETEK Mansfield & Green (North America)
Tel: +1 800 527 9999 • cal.info@ametek.com

AMETEK Singapore Pte. Ltd. (Singapore)
Tel: +65 6 484 2388 • aspl@ametek.com.sg

AMETEK Inc. Beijing Rep. Office (China)
Tel: +86 10 8526 2111 • jofra@ametek.com.cn

AMETEK GmbH (Germany)
Tel: +49 2159 9136 510 • info.mct-de@ametek.de

AMETEK Calibration Instruments (UK)
Tel: +44 (0) 1489 486 404 • jofra@ametek.co.uk