

TGA-B™

Periodic On-line Partial Discharge Monitoring Using a
Portable Instrument for Motors and High Speed Turbine Generators



A USER'S PERSPECTIVE:

"Since economics and time do not allow plant personnel to repair all suspect motors, on-line partial discharge analysis allows users to compare motors and gauge degradation to determine which motors pose the greatest risk of failure..."

PERIODIC ON-LINE PARTIAL DISCHARGE MONITORING OF MOTORS & TURBINE GENERATORS

The test enables predictive maintenance on motor and turbine generator stator windings, resulting in increased availability and extension of operating life. The technique was introduced over two decades ago and has since been applied to over 6000 motors and turbine generators to identify deteriorated stator windings. It is by far the most popular method in the world for measuring motor and generator partial discharge (PD).

The method is non-destructive and based on sound scientific and

empirical principles, and is recommended by manufacturers and industry standards such as the IEEE Std. 1434-2000.

The monitoring technique is based on the application of 80pF capacitive couplers, resulting in a high frequency measurement range and favorable signal-to-noise ratio. This enables the automatic separation and recording of both partial discharges and electrical noise, so that test results can be easily interpreted by users.

The most common method of monitoring motors and turbine generators involves using the TGA-B™ portable instrument with multiple sets of permanently installed capacitive couplers. The instrument is controlled by means of a computer and includes Windows™-based control and data display software.

Alternatively, continuous monitoring systems are available from Iris Power. They can be integrated with plant SCADA and facilitate remote monitoring.

MOTOR AND TURBINE GENERATOR TESTING

The 80pF capacitive bus couplers block the 50/60Hz power frequency voltage allowing high frequency fast rise-time voltage pulses (which are caused by partial discharges in the winding) to pass through. Couplers are normally installed in a "directional" configuration (see diagram). For motors and generators connected directly to the power system via air-insulated buses, two couplers are installed on each phase: one at the terminals of the motor or generator, and one further down the line towards the system. The length of the coaxial cable connected to each coupler is equal. The delay and the direction of pulse propagation between the couplers determine the origin of the pulses. Consequently, the system can digitally distinguish between power system noise and winding partial discharge.

Motors or generators connected to long lengths (>30m) of shielded power cable may require only one coupler per phase to be installed in the machine terminal box. In this case, stator winding PD is separated from external noise by the shape of the detected pulse.

For large hydrogen-cooled generators, sparking may also occur in the stator core or at the machine terminals that may cause false indications. In this situation, the preferred PD measuring system uses stator slot couplers (SSCs) and the TGA-S™ instrument.

The TGA-B system can also be applied to monitor the partial discharges in switchgear and dry-type transformers.

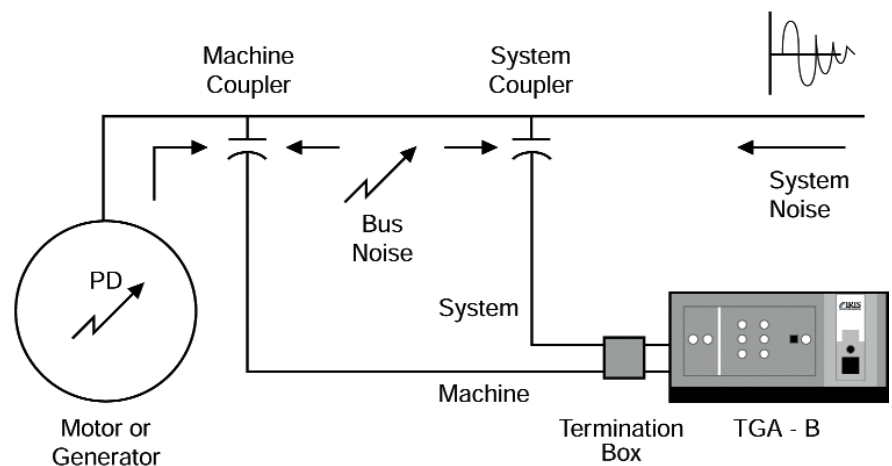

Directional Bus Coupler Configuration for Motors and Generators

TGA-B SYSTEM TEST PROCEDURE

With the motor or generator operating under normal service conditions, the operator connects the TGA-B instrument to a coupler termination box and to a portable computer running the Iris Power software. The magnitude, phase position and number of partial discharge pulses detected at each coupler are then recorded and can be viewed immediately, or stored for a subsequent analysis.

The results presented to the user include:

- graphs depicting the nature and severity of particular insulation aging mechanisms
- trend curves highlighting the progression of these mechanisms over time
- statistical values which can be compared with historical databases for similar units.

In most cases, assessment of the stator winding insulation condition, based on the on-line partial discharge measurement, can be performed independently by the user after a short training course. Iris Power can also assist the user with data interpretation using its unique database of over 140,000 results collected over 20 years on motors and generators of all makes and sizes.

PLANNING PREDICTIVE MAINTENANCE USING ON-LINE PARTIAL DISCHARGE MONITORING

Stator winding insulation problems account for about 40% of all motor and air-cooled generator forced outages, which result in lost revenues. On-line partial discharge monitoring, a proven technique developed by Ontario Hydro and the Canadian Electrical Association, helps to minimize the risks of unexpected stator winding failure. Using permanently installed couplers and a portable instrument (the TGA-B), plant personnel worldwide have found this method reliable and easy to use.

In the last 20 years, the on-line partial discharge test has produced results on thousands of motors and generators. Published case studies by dozens of TGA test users have confirmed the following benefits:

- the root causes of stator problems can be identified and often repaired at an earlier stage
- monitoring can increase the availability of equipment, and can contribute to the extension of the useful life of the unit windings
- intervals between generator and motor inspection outages can be increased if the TGA results are good
- most stator winding in-service failures can be avoided
- there is an exceptionally low risk of false indications
- clear levels at which machines need maintenance have been established
- can be applied to existing and new machines.

HOW THE TGA-B™ SYSTEM MEASURES AND ANALYZES PARTIAL DISCHARGES

The TGA-B test has been designed to monitor partial discharges during normal electrical, mechanical, thermal, and environmental operating stresses. The readings are not affected by external interference (or noise) such as power system corona, output bus arcing or other common noise sources. The tests are typically performed semi-annually and take about 30 minutes per machine.

BUS CAPACITIVE COUPLERS

The TGA-B instrument is used in conjunction with 80pF, high voltage capacitors, permanently installed at specific locations external to the machine. Iris Power supplies the compact capacitive couplers made of high quality mica splittings, encapsulated in a specially formulated epoxy compound. These couplers are certified to be discharge free at twice the operating voltage and are resistant to surface tracking.



Installed 80pF PD Couplers

DETECTION OF PARTIAL DISCHARGES

Partial discharges in degrading high voltage stator windings give rise to small voltage pulses which travel through the stator winding. The magnitude and the number of these pulses depend on the degree of insulation deterioration. That is, as the magnitude and number of partial discharge voltage pulses increase, the rate of the electrical insulation deterioration also increases. The partial discharge signals are often mixed with electrical noise from sources such as corona and output bus arcing, but are separated for analysis by the TGA-B instrument.

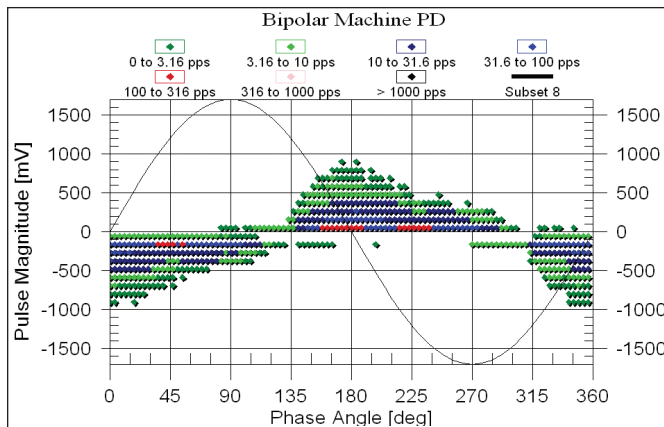

PD in Stator

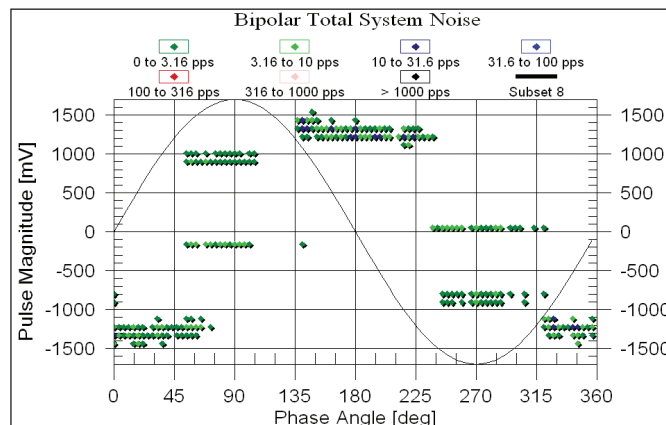

External Noise

WORLDWIDE INDUSTRY ACCEPTANCE OF ON-LINE PD MONITORING

The partial discharge test has won worldwide acceptance with most major utilities and petrochemical companies. This general acceptance has been achieved because:

- the test has been proven effective in thousands of installations, by identifying motors and generators which require maintenance
- the test equipment is cost-effective
- the test is performed on-line and requires no machine shut-down
- plant staff can perform the test, and interpret test results with minimal training.

TGA-B and TGA-S are trademarks of Iris Power LP.
Windows is a registered trademark of Microsoft Corporation in the United States and other countries

IRIS POWER LP HAS BEEN THE WORLD LEADER IN MOTOR AND GENERATOR WINDING DIAGNOSTICS SINCE 1990, PROVIDING A FULL LINE OF ON-LINE AND OFF-LINE TOOLS, AS WELL AS COMMISSIONING AND CONSULTING SERVICES.



HEAD OFFICE
IRIS Power LP
3110 American Drive
Mississauga, ON L4V 1T2
Canada
Phone: 1-905-677-4824
Fax: 1-905-677-8498

irispower.com
sales@irispower.com

